

KITCHEN & BATH INTERIOR

**CMMA SOLID SURFACE**

( Acrylic & Polyester )

**MMA-100 SOLID SURFACE**

( 100% Pure Acrylic )

[www.WorldBMC.com](http://www.WorldBMC.com) [English]  
[www.WorldBMC.co.kr](http://www.WorldBMC.co.kr) [Korean]



**WORLD BMC Co., Ltd.**

## 01 Description

- **CMMA (Compound Methyl MethAcrylate)** is a brand of World BMC's proprietary, eco-friendly solid surface. CMMA product line (Acrylic and Polyester Hybrid Solid Surface) includes all molded and ready-made goods.
- **MMA-100 (Methyl MethAcrylate)** is a 100% acrylic solid surface brand designed by World BMC. MMA-100 product line comprises sheet material goods, so it can do custom fabrication.

## 02 Characteristics

### CMMA

- High yield capacity (Mass production)
- Best impact resistance and lightweight
- Superior heat and cool resistance
- Easy installation

### MMA-100

- Superior stain and chemical resistance
- No visible lines at the seams
- Color stability
- Best weather resistance

## 03 Applications

- Sink Top Table
- Vanity Top
- Plate Slab
- Wall Panel
- Sink Bowl
- Floor Panel

## 04 Property Data



PROPERTY	UNIT	TEST METHOD	DATA
Specific Gravity	-	ASTM D792	1.624
Barcol Hardness	-	JIS K 6911	50
Water Absorption	%	ASTM D570	0.025
Tensile Strength	kgf/cm <sup>2</sup>	ASTM D638	323
Flexural Strength	kgf/cm <sup>2</sup>	ASTM D790	736
Compressive Strength	kgf/cm <sup>2</sup>	ASTM D695	933
Izod Impact Strength	kgfcm/cm	ASTM D256	23.1
UL 94 - Flammability		UL 94	V - o
Total Volatile Organic Compounds (TVOCs)			0.142
Toluene		Standard test Method for indoor Air Quality small Chamber test (Ministry of Environment act 2008-73)	0.003
Formaldehyde(HCHO)	mg/m <sup>3</sup> .h		0.007

## SINK TOP TABLE

### 01 Sink Top Table(—Shape) : 50BH TYPE

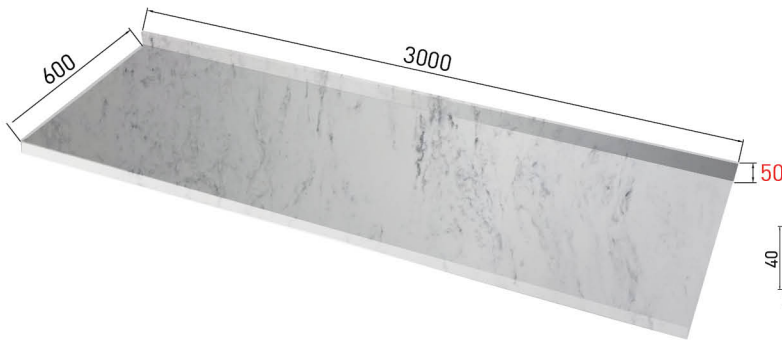

MM 3,000L×600W×50BH  
Inch 118L×24W×2BH

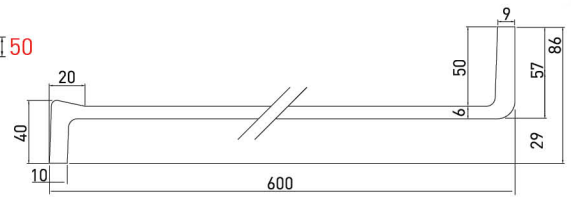

### 02 Sink Top Table(—Shape) : 100BH TYPE

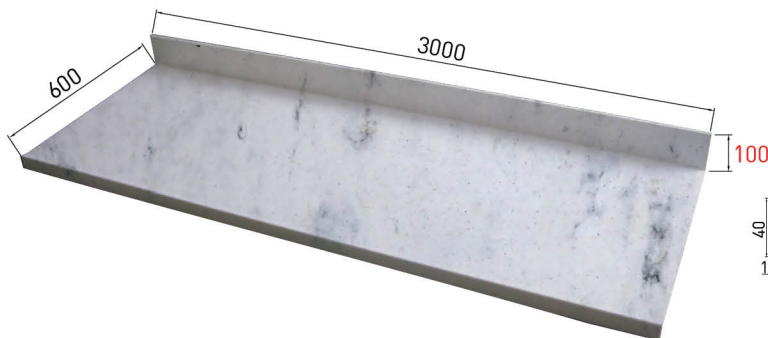

MM 3,000L×600W×100BH  
Inch 118L×24W×4BH

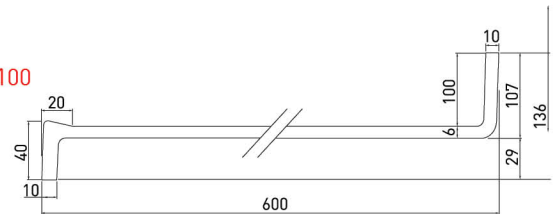

### 03 Sink Top Table(┐,└Shape) : 50BH TYPE

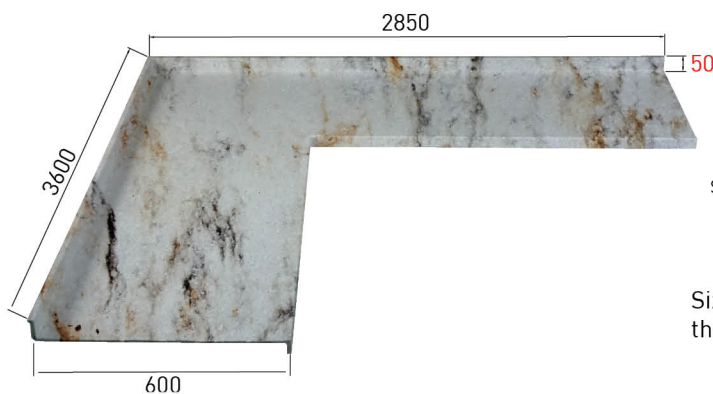

MM 3,600L×2,850L×600W×50BH  
Inch 142L×112L×24W×2BH

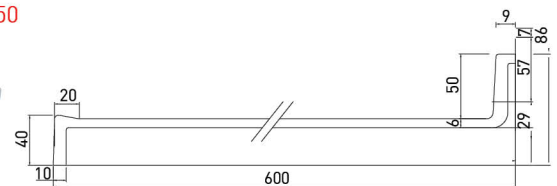

Size and shape selection is available according to the kitchen direction.

# PLATE SLAB

## 01 Plate Slab 1



**MM** 2,550L×770W×3~10T  
**Inch** 100L×30W×0.11T~0.39T

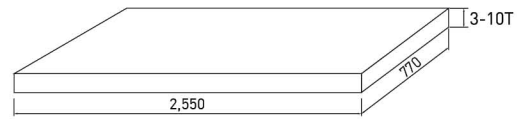

## 02 Plate Slab 2



**MM** 1,220L×1,000W×3~10T  
**Inch** 48L×39W×0.11T~0.39T

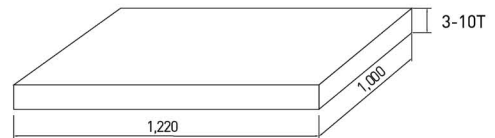

## 03 Plate Slab 3



**MM** 1,100L×800W×2.5~10T  
**Inch** 43L×31W×0.11T~0.39T

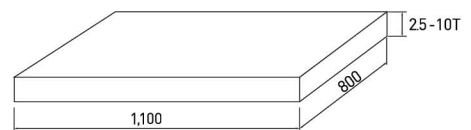

It can be installed on the wall and the top part of the sink to show elegance.

# OTHERS

## 01 Island Top Table

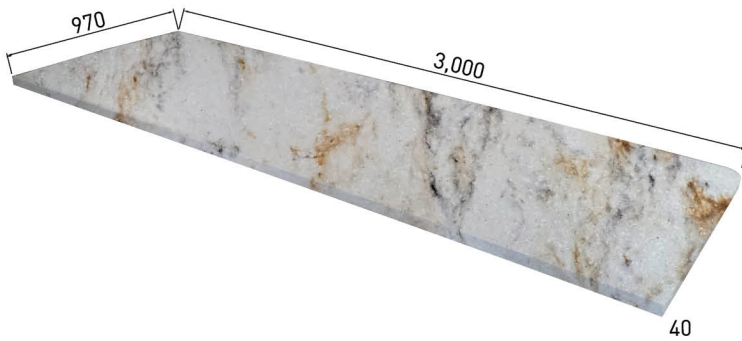

MM 3,000L×970W×40H  
Inch 118L×38W×1.6H

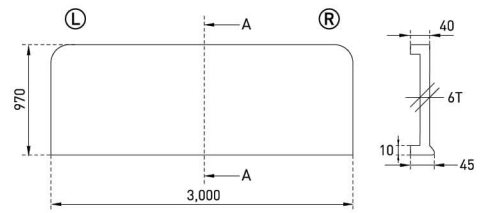

## 02 Dining Table

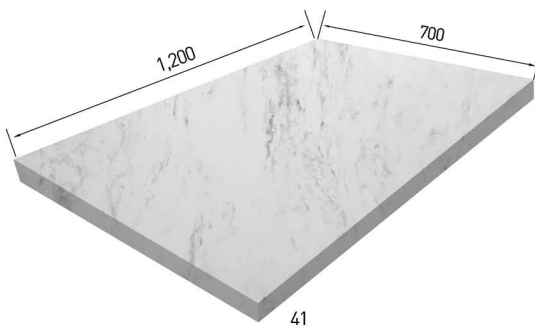

MM 1,200L×700W×41H  
Inch 47L×28W×1.6H

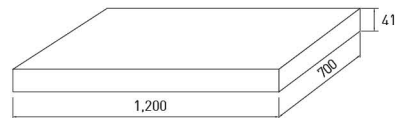

## 03 Vanity Bowl



MM 1,000L×180W×130H  
Inch 39L×7W×5H

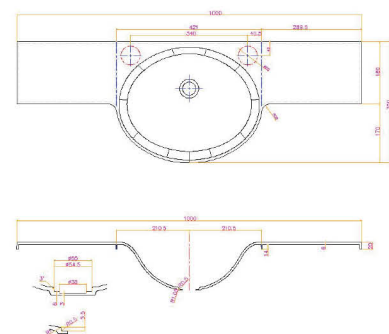

# VANITY TOP

01 Vanity Top 1



MM 1,850L×600W×180H  
Inch 73L×24W×7H

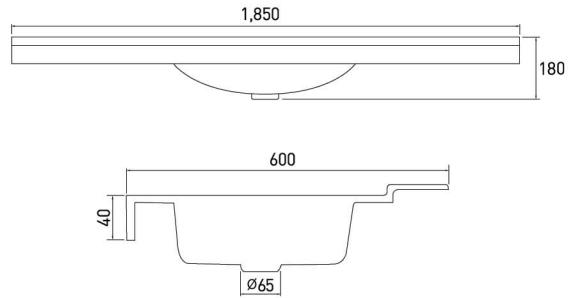

02 Vanity Top 2



MM 1,500L×600W×147H  
Inch 59L×24W×6H

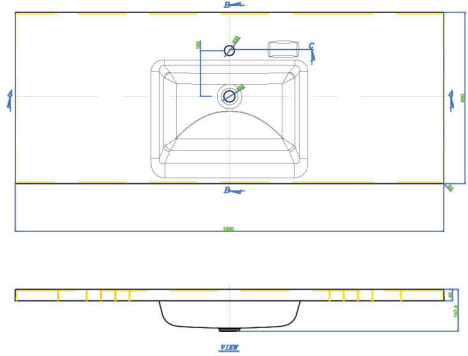

03 Vanity Top 3



MM 635L×480W×180H  
Inch 25L×19W×7H

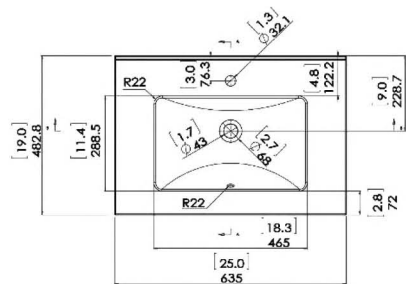

# WALL PANEL

## 01 Product

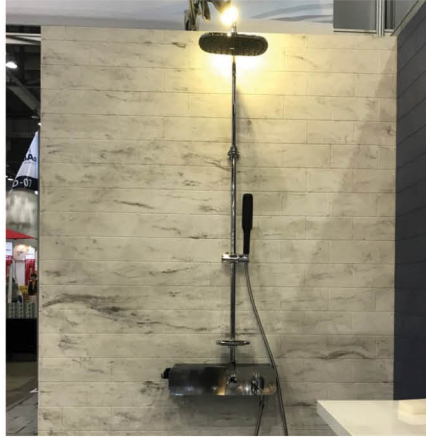

SIZE 5ft(1,524)×8ft(2,440)  
Thickness 3.5~5T  
Block size 100mm×200mm

## 02 Shower Wall Drawing

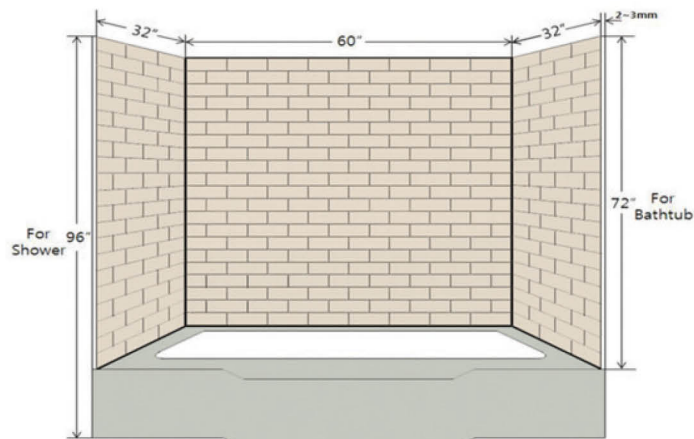

## 03 Wall Panel application

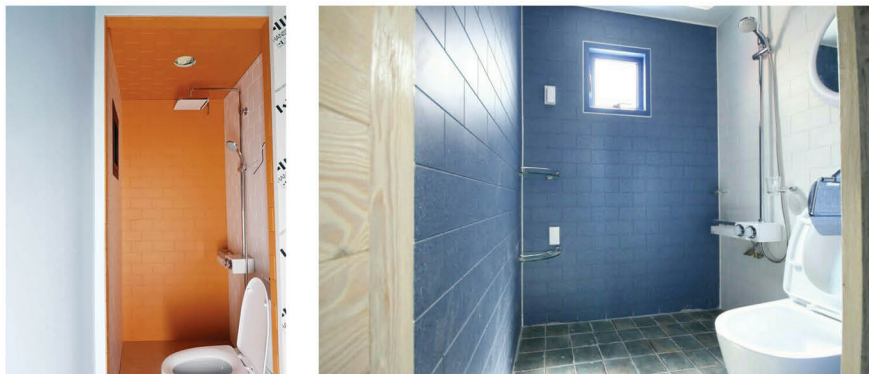

SINK BOWL

01 Jumbo Bowl 4987



MM 870L×490W×225H  
Inch 34L×19W×9H

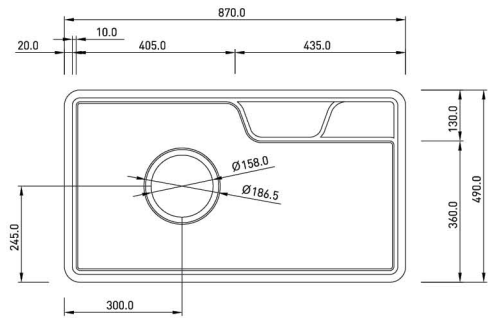

02 Double Bowl 4887



MM 870L×480W×220H  
Inch 34L×19W×9H

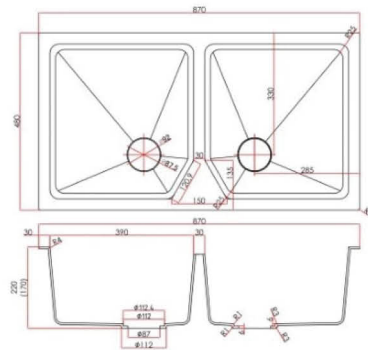

03 Mini Bowl 5151



MM 510L×510W×220H  
Inch 20L×20W×9H

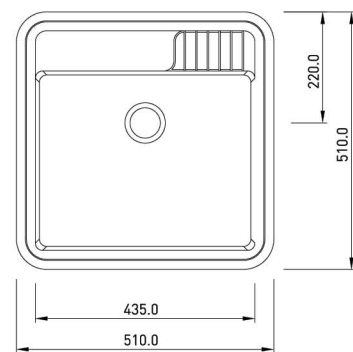



# STRAINER

## 01 Jumbo Bowl



## 02 Mini Bowl / Double Bowl



## FABRICATED PRODUCT

01 Preformed Kitchen Top1 (1,200Lx600W)



02 Vanity Top1 (900Lx560W)



03 Preformed Vanity Top2



04 Fabricated Sink Top Table



05 Preformed Vanity Bowl



06 Vanity Bowl (350Dx400W)



## GLUE

01 Super Glue



02 Acrylic Glue Tube 70ml



03 Acrylic Glue Cartridge 75ml



04 Silicone



# HEAT & IMPACT TEST

## HEAT (OIL) TEST

Temp. 190~200°C / Time: 10min



WORLD BMC CO.,LTD.

## HEAT (IRON) TEST

Temp. 190~200°C / Time: 10min

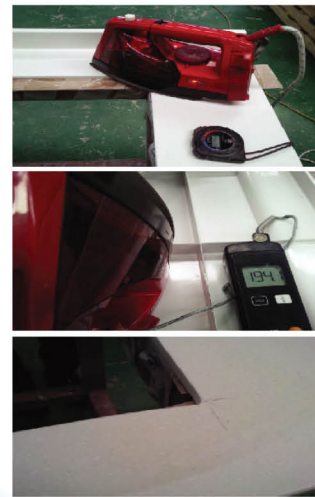

WORLD BMC CO.,LTD.





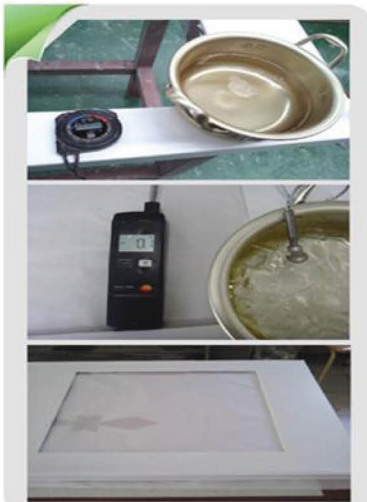



## COOLING TEST

Temp. 0~-10°C / Time: 10min



WORLD BMC CO.,LTD.

## IMPACT TEST

MMA Solid Surface	Polyester Solid Surface	CMMA Solid Surface
Real Product	Real Product	Real Product
		
Test Method (With Hammer)	Test Method (With Hammer)	Test Method (With Hammer)
		
Test Result (After 1 hit by Hammer)	Test Result (After 1 hit by Hammer)	Test Result (After 14 hits by Hammer)
		

WORLD BMC CO.,LTD.

COLOR

01 Classic Collection



White 2

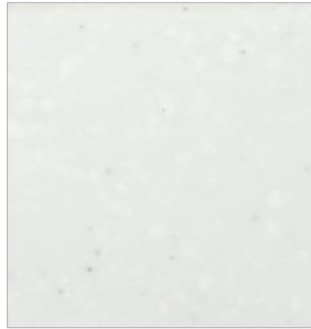

Magner White

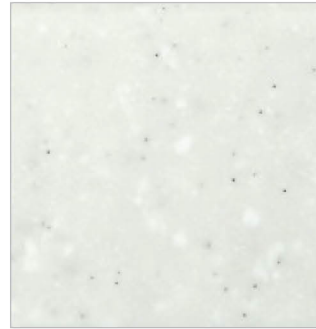

Snow White



Almond Terrazo



Dalmatian

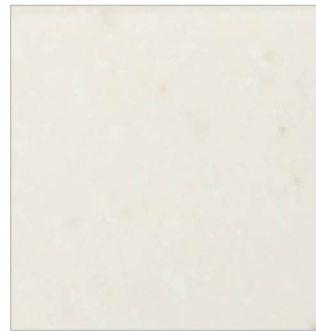

Abalon

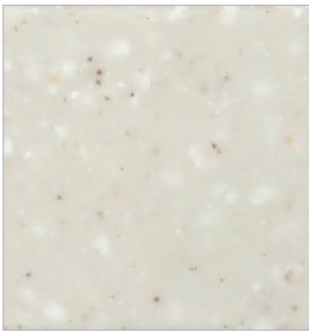

Nut Brown

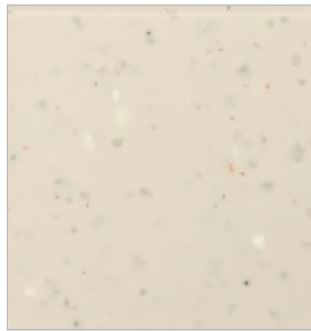

Walnut

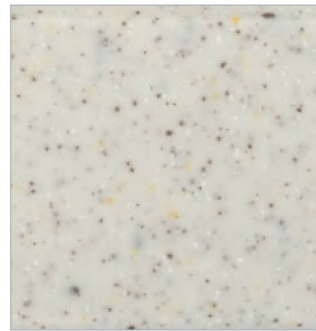

Zen TF



Bean Brown



Mist

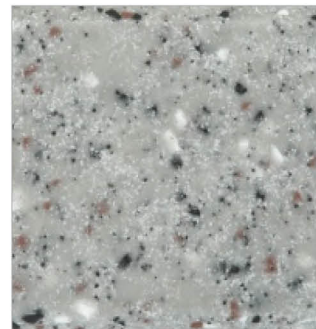

Stone Grey

02 Marble Collection



Point Cream



Point White



Point Rock



Point Stone

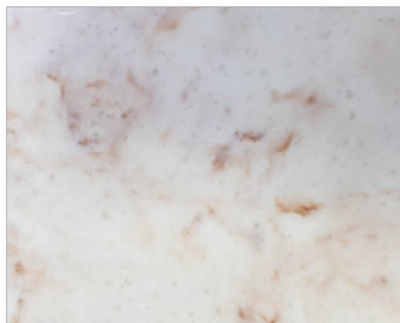

Point Cherry



Point Beige



Point Gold



Point Grey

## APPLICATION FOR CMMA CLADDING

01 Wall Panel in the Bathroom



02 Wall Panel in the Showroom



03 Deco Panel in the Interior



04 Deco Panel in the Interior



05 Renga Zendai



06 Cladding of Cabinet Door



## APPLICATION

### 01 "—" Shape Sink Top Table



### 02 Plate Slab (Solid Surface Sheet)

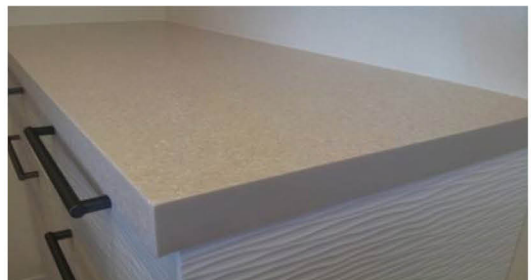

### 03 "L" Shape Sink Top Table



### 04 Island Top Table

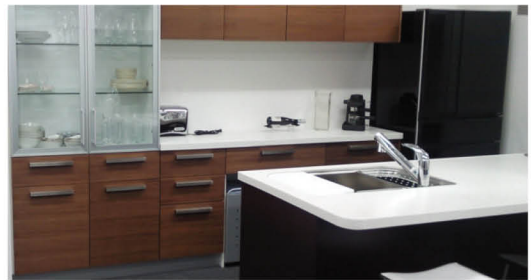

### 05 Vanity Top



### 06 Laundry Bowl



## INSTALLATION GUIDELINE

### Cutting



### Cutting (Hole)



### Attaching (Glue)



### Attaching (Edge)



### Attaching (Wood)



### Attaching (Sink Bowl)



### Attaching (Finish)



### Setting in Kitchen





# PRODUCTION PROCESS

## 01 Machines



2000ton press



1000ton press



Mold of Sink Bowl

## 02 Products



Sink Top Table(—)

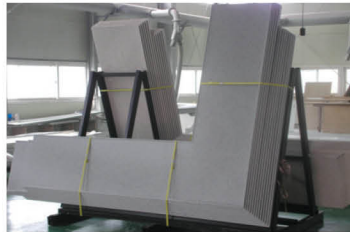

Sink Top Table(┐)

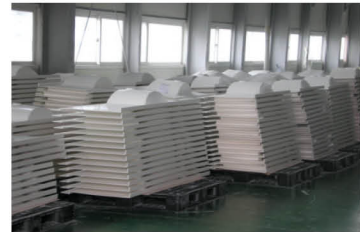

Vanity Top

# RESEARCH & DEVELOPMENT



UTM Tester



Impact Tester



Proof Piece Mold



UV Weather Meter



Color Meter



Test Mold & Press

100% Pure Acrylic Solid Surface

# MMA-100

## FEATURES

- 01 Sensual Interior creation is possible
- 02 Workability is excellent (Cut ▶ Joint ▶ Polishing)
- 03 Strong to heat, moisture, contamination and bacteria
- 04 Easy maintenance and hygienic clean
- 05 Size : 760mm x 3680mm x 12mm

## PRODUCTION PROCESS



# APPLICATION

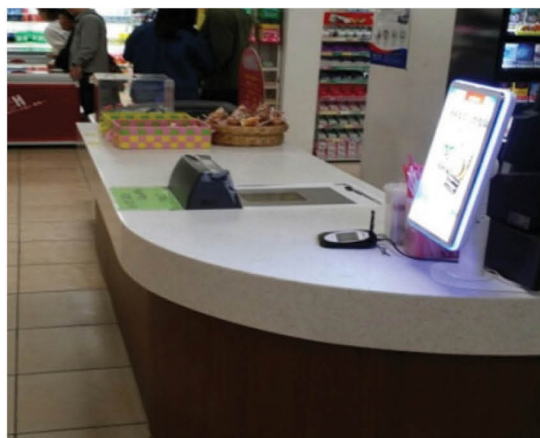

MANAGEMENT CERTIFICATE



Certificate of ISO 9001

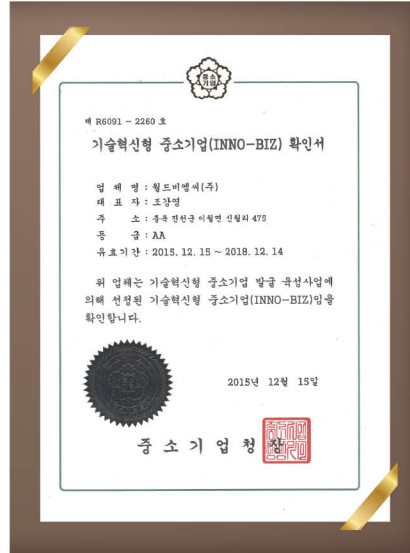

CERTIFICATE OF INNO-BIZ



Certificate  
KOTRA GLOBAL BRAND



Shikh ZAYED program for  
housing by Goverment of Arab Emirates

# CMMA CERTIFICATE

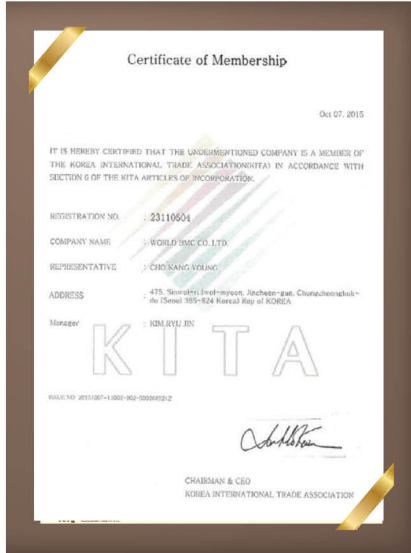

Certificate  
KOREA INTERNATIONAL  
TRADE ASSOCIATION



Certificate of Patent



Certificate of Trademark

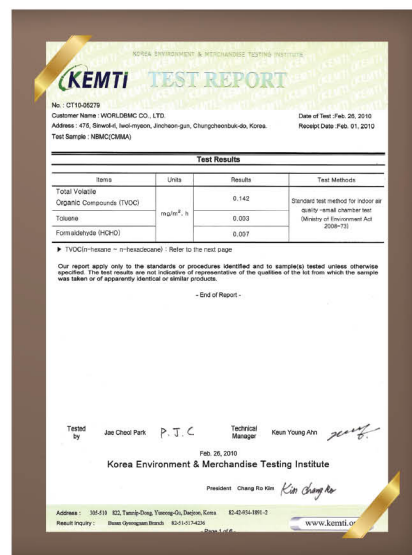

TVOC & HCHO

CMMA CERTIFICATE

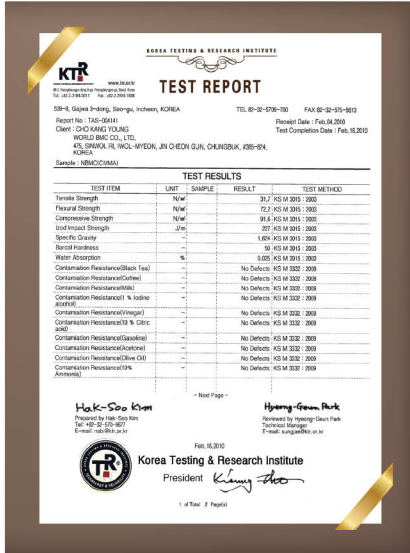

Mechanical Properties

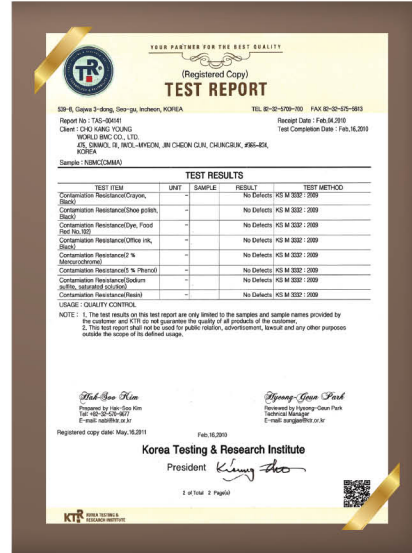

Resistance Stain Properties

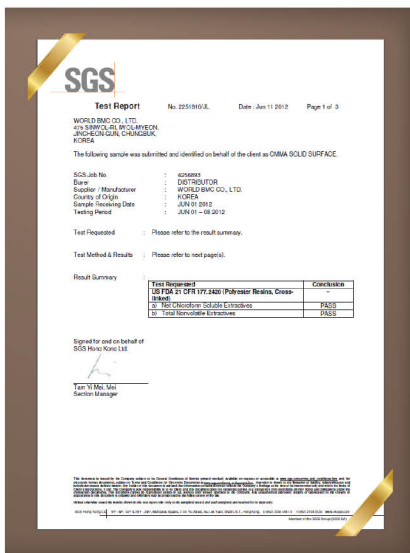

US FDA 21 CFR177.2420 (Polyester Resin, Cross-linked) Test

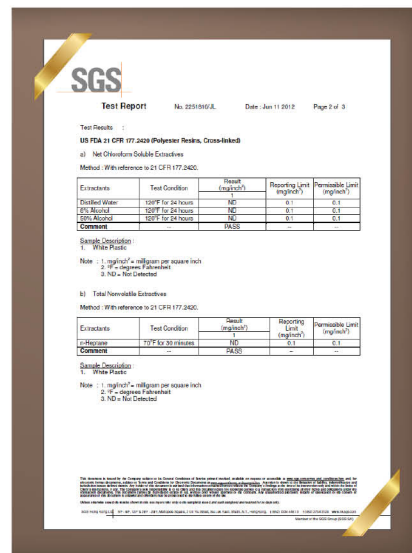

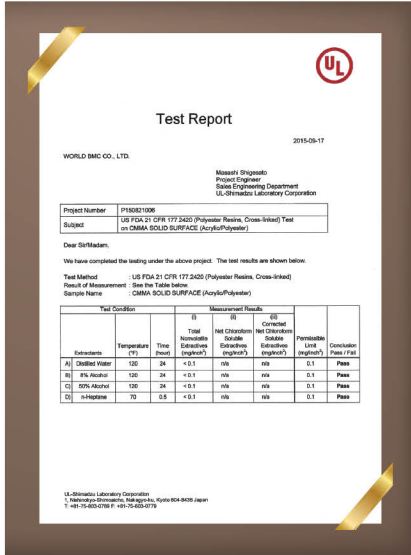

US FDA 21 CFR177.2420

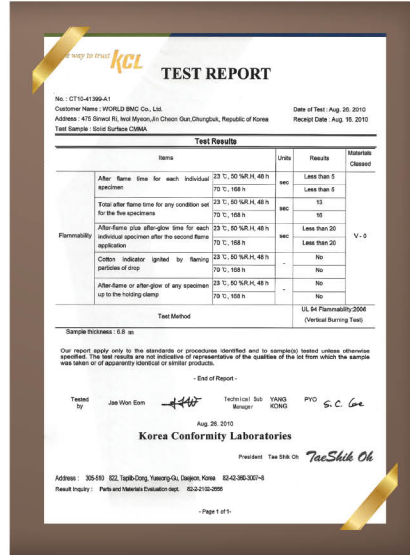

Flame retardant

# MMA100 CERTIFICATE

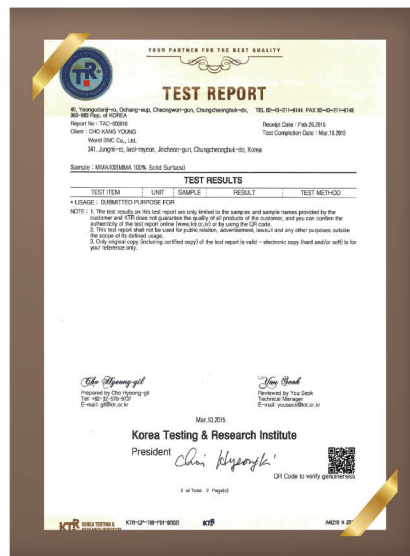
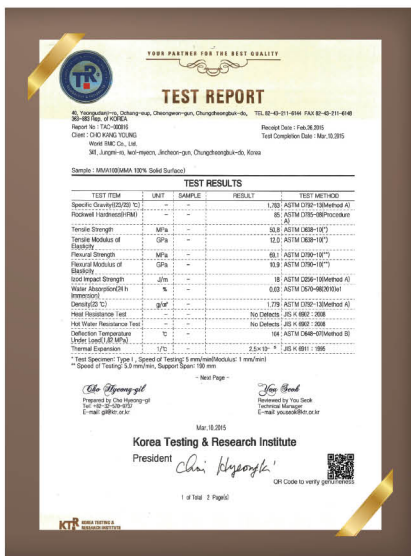

### **UAE Branch**

RAK Free Zone PO BOX;16111  
Ras Alkhaimah UAE

**Tel :** 00971 65266833

**Fax :** 00971 65285752

**Mob :** 00971 505236287

**Web :** [www.WorldBMC.com](http://www.WorldBMC.com) [English]

**E-mail :** [Tashyeed.gt@gmail.com](mailto:Tashyeed.gt@gmail.com)

### **Headquarters / R & D Center**

341 Jungmi-ro Iwol-myeon Jincheon-gun  
Chungcheongbuk-do, Republic of Korea 27816

**Tel :** +82-43-533-2468

**Fax :** +82-43-533-2464

**Web :** [www.WorldBMC.co.kr](http://www.WorldBMC.co.kr) [Korean]

[www.WorldBMC.com](http://www.WorldBMC.com) [English]

**E-mail :** [wbmc2002@hanmail.net](mailto:wbmc2002@hanmail.net)

### **US Branch**

20280 South Vermont Ave. Suite 200  
Torrance CA. 90502 USA

**Tel :** +1-650-847-8332

**Fax :** +1-310-532-8799

**Web :** [www.WorldBMC.com](http://www.WorldBMC.com) [English]

**E-mail :** [Julia@worldbmc.com](mailto:Julia@worldbmc.com)